



# Tee Splice Connection Kit Installation Instructions

## (SR-SFIT-TEE)

For use with Warmup WSR Parallel Self-Regulating Cable  
Non-hazardous and Hazardous Locations

<b>Model</b>	WSR- <b>&lt;a&gt;</b> W- <b>&lt;c&gt;</b> - <b>&lt;XXX&gt;</b> d			
<b>Code</b>	WSR- <b>&lt;a&gt;</b> <b>&lt;b&gt;</b> W- <b>&lt;c&gt;</b> - <b>&lt;XXX&gt;</b> d			
	<b>&lt;a&gt;</b> = 5, 8, 10 W/ft W/ft insulated pipe @50°F (10°C)	<b>&lt;b&gt;</b> = 9, 12, 15 W/ft W/ft in water @32°F (0°C)	<b>&lt;c&gt;</b> = 1 / 2 1 = 110-120 V AC 2 = 208-277 V AC	<b>&lt;XXX&gt;</b> = 250, 500 or <b>1000ft</b> Cable length
				<b>&lt;d&gt;</b> = CR Outer jacket material

## Kit & Cable Description

Warmup's Tee Splice Connection Kit [SR-SFIT-TEE] is designed for safe and reliable 3-way Tee-Splice connection of Warmup's WSR Self-Regulating Cable. Each kit can complete one Tee-Splice connection. Once the connection has been completed the kit is low profile so can be installed on pipe under insulation.

Warmup's WSR Self-Regulating Cable features an advanced positive temperature coefficient [PTC] self-regulating core is positioned between two 16 AWG multi-strand tinned copper bus wires. These are then insulated with a modified polyolefin layer which is wrapped in a tinned copper braid for grounding.

The cable's outer jacket, made from modified polyolefin, ensures superior resistance to UV, abrasion, chemical, and mechanical wear, enhancing durability in harsh conditions.

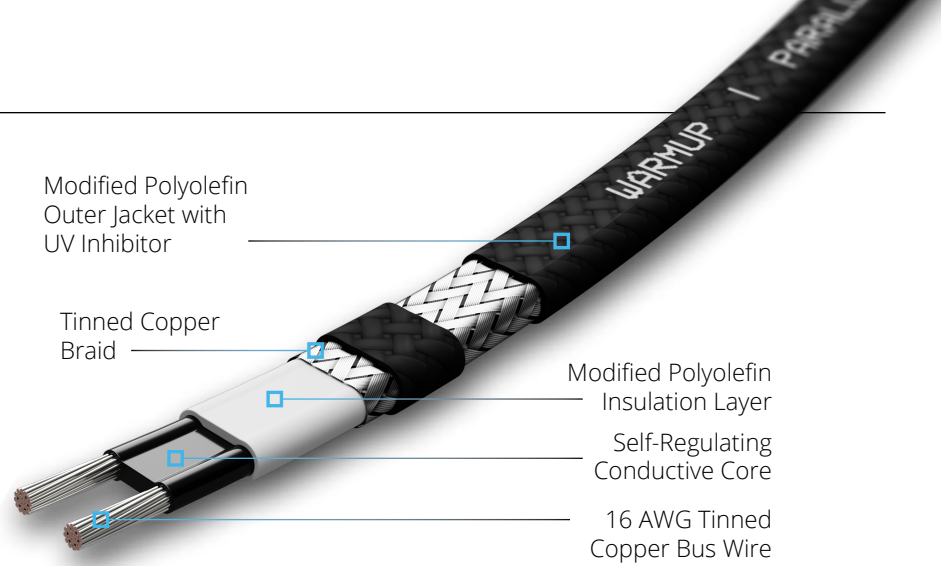



## SR-SFIT-TEE - Approved Applications



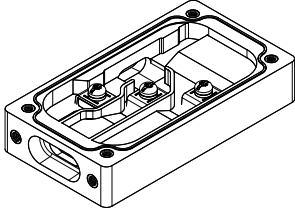
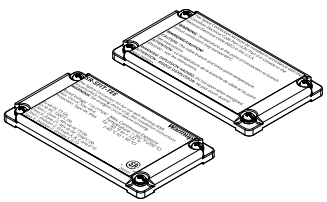
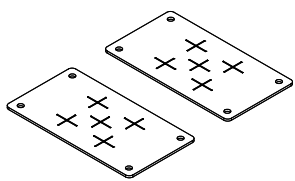
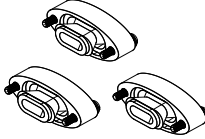
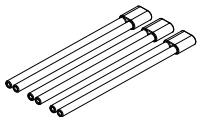
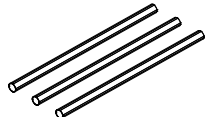

<b>Ordinary and Hazardous Locations</b> †	<b>Per US (NEC 500) and CA (CE Code Annex J18)</b>	
	Class I, Division 2, Groups A, B, C and D, T3	Class II, Division 2, Groups F and G, T3
	<b>Per US (NEC 505)</b>	
	Class I, Zone 1 AEx eb IIC T3 Gb	Class II, Zone 21 AEx tb IIIC T200°C Db
	<b>Per IECEx/ATEX standards</b>	
	Ex 60079-30-1 IIC T5/T6 Gb	Ex 60079-30-1 IIIC T100°C/T85°C Db

† For hazardous locations, WSR self-regulating cable MUST be installed with Warmup approved accessories for hazardous locations

## Kit Components

<p>1 x Connection Box</p>		<p>2 x Back Cover with Captive Screws</p>	
<p>2 x Watertight Sealing Gasket</p>		<p>3 x Pressure End Seals with Captive Screws and Watertight Sealing Grommets</p>	
<p>3 x Silicone rubber boot 1/8" ID x 6" (3.5mm x 150mm)</p>		<p>3 x Green &amp; Yellow Heat-Shrink Tubes 1/4" ID x 6" (7 mm x 150 mm)</p>	
<p>3 x Warning Labels</p>			

## Receiving, Storing and Handling

-  Identify components against the packing list to ensure the proper type and quantity has been received check corresponding documentation.
-  Inspect components for damage incurred during shipping.
-  Components should be checked to verify catalogue type, power rating, voltage rating, and quantity.
-  Components should be examined to verify compatibility with the environmental elements that might be encountered. Special consideration should be given to the area of installation (indoor versus outdoor) and where applicable, the components should be appropriately rated for the intended application. Refer to the kit markings.
-  Components should be stored in clean, dry areas and should not be released to the field until they are needed for construction so as to minimize inadvertent damage.

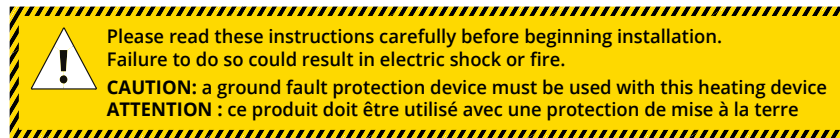

-  Before installation, servicing or maintenance, the cables MUST be de-energised. The branch-circuit switch or circuit breaker supplying the equipment shall be placed in the OPEN (OFF) position and secured with a lockout device. This lockable disconnecting means shall simultaneously disconnect all ungrounded conductors and must comply with NEC/CEC requirements.
-  To reduce the risk of shock or fire ground-fault equipment protection with a 30mA trip level must be installed on each heating cable branch circuit. Ground-fault equipment protective devices intended for use with self-regulating heating cable circuits in Division areas shall be appropriately identified for use in Division areas.
-  The self-regulating cable and its components must be installed in accordance with the National Electrical Code [NEC] and Canadian Electrical Code [CEC] and any other applicable national and local codes. Review their requirements prior to installation.
-  When installation is complete, an insulation resistance test should be conducted with a test voltage of at least 500 V dc using a megohmmeter between the self-regulating cable bus wires and the metallic braid. IEEE 515.1 recommends that the test voltage for polymer insulated heating cables be 2500 Vdc. Minimum resistance should be 20 MΩ. After the application of thermal insulation, the measured value of the entire branch circuit should not be less than 5 MΩ.
-  The tinned copper braid must be connected to a suitable grounding/earthing terminal.
-  The equipment [cable and components] shall not be installed in a location where the external conditions are conducive to the build-up of electrostatic charge on such surfaces. In addition, the equipment shall only be cleaned with a damp cloth and shall be cleaned regularly to prevent dust accumulation.
-  Bus wires will short if they contact each other. Keep bus wires separated. Damage to the bus wires can result in overheating or short circuits. Take care when removing the jacket or core insulation to prevent damage to the braid or bus wires.
-  Do not replace or substitute the grommet. Only the components supplied in the SR-SFIT-TEE are approved for use. Using an incorrect grommet may cause leaks, damage to components, electric shock, or dielectric failure, and will void all approvals and certifications.
-  Ensure you have the correct type of Warmup components for your installation. To maintain cCSAus compliance, only Warmup approved components may be used with WSR Self-Regulating Cable.
-  When the process temperature is 302°F (150°C), service temperature of cable entry and branch point are:  
**Cable entry:** 338.31°F (170.17°C)  
**Branch point:** 355.33°F (179.63°C)  
**Note:** End user shall select a suitably Certified cable and cable gland for final installation
-  The equipment [cable and components] shall be installed such that the cable is protected from mechanical damage. The cable shall not be subjected to tension or torque. If the cable is to be terminated within an explosive atmosphere, then the free end shall be terminated in a suitably certified termination. Junction boxes shall be installed in a low mechanical risk position.
-  The SR-SFIT-TEE was submitted to clamping tests corresponding to the 25% of tensile value in clause A.3.1.1 of CSA/UL 60079-0, so when installing you MUST provide additional and effective clamping of the cable to ensure that pulling is not transmitted to the terminations and prevent pulling and twisting after installation.
-  Ensure that you have the correct type and size of self-regulating cable for your installation (wattage output and voltage rating). Ensure that connection kits and cable ends are kept dry before and during installation.
-  Connections should not be located in an area where moisture is present and should not be located at the lowest point of downspouts.
-  The minimum bending radius of the cable is 1¼" (30 mm). Do not bend on the narrow axis.
-  DO NOT connect power to the cable while it is on the reel.
-  The minimum installation temperature for the cable is -4°F (-20°C) when use with integral component kits and -40°F (-40°C) when use with enclosure kits.
-  The presence of the self-regulating cable shall be made evident by the posting of warning signs where clearly visible. For Roof & Gutter applications apply with supplied warning label on circuit breaker panels, contactor panels and junction boxes. For Pipe Trace applications, warning labels at intervals not exceeding 6 m (20 ft) along the pipeline or vessel and on or adjacent to equipment in the piping system that requires periodic servicing.
-  Persons involved in the installation, testing and maintenance of self-regulating heating systems shall be suitably trained in all special techniques required. Installations are intended to be carried out under the supervision of a qualified persons.
-  The person(s) responsible for installation shall verify that the installation and inspection are performed by personnel who are trained, qualified, and knowledgeable in trace heating systems when using the Division/Zone method of area classification. The installation and inspection shall be in accordance with Warmup's design documents, product recommendations, and installation instructions.
-  The proposed installation shall be verified for the proper selection of self-regulating cable and component systems identified for the application; i.e. Class and Division/Zone. Warmup's documentation shall be reviewed for specific installation requirements and the proposed installation shall be verified that the heating system is compatible with the environment.
-  Leave these installation instructions with the user for future reference. The self-regulating heating system [cable and components] documentation shall be retained for each self-regulating heating circuit for as long as the system is in use.
-  The SR-SFIT-TEE instructions must be used with reference to the installation instructions for the WSR Self-Regulating cable.

## Tools Required for Installation

- Pliers
- Utility Knife
- Natural Cure, Single Part RTV Adhesive
- Screwdriver
- Measuring Tape
- Heat gun
- Wire Cutters
- Glass Cloth Tape

## Installation

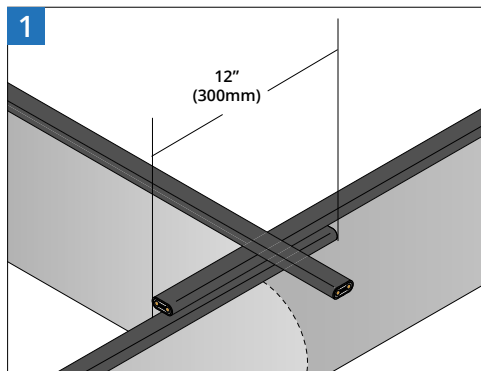

- Overlap the ends of the cable by at least 12" (300mm). This will ensure there is sufficient cable to reach terminals of the connection box and excess cable for future works.

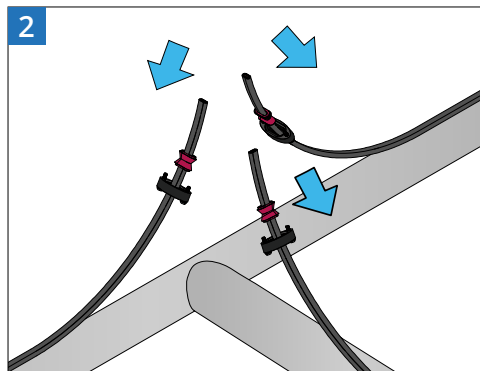

- Place the SR-SFIT-TEE grommets and sealing glands over each cable in the order shown.

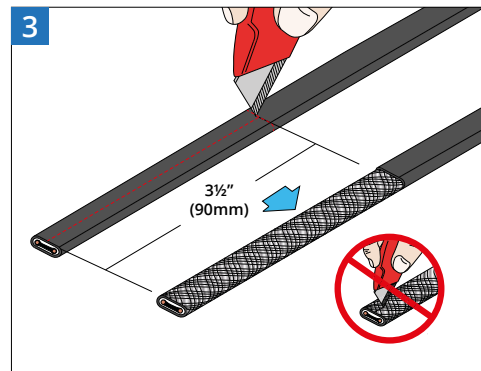

- Measure and mark approximately 3½" (90mm) from the end of the cable on the outer jacket.
  - Lightly score the outer jacket as shown, ensuring you DO NOT cut the ground braid or inner jacket. Bend the cable to break the outer jacket.
- NOTE:** It is better to do multiple shallow scores to the outer jacket than go too deep and cut the braid.

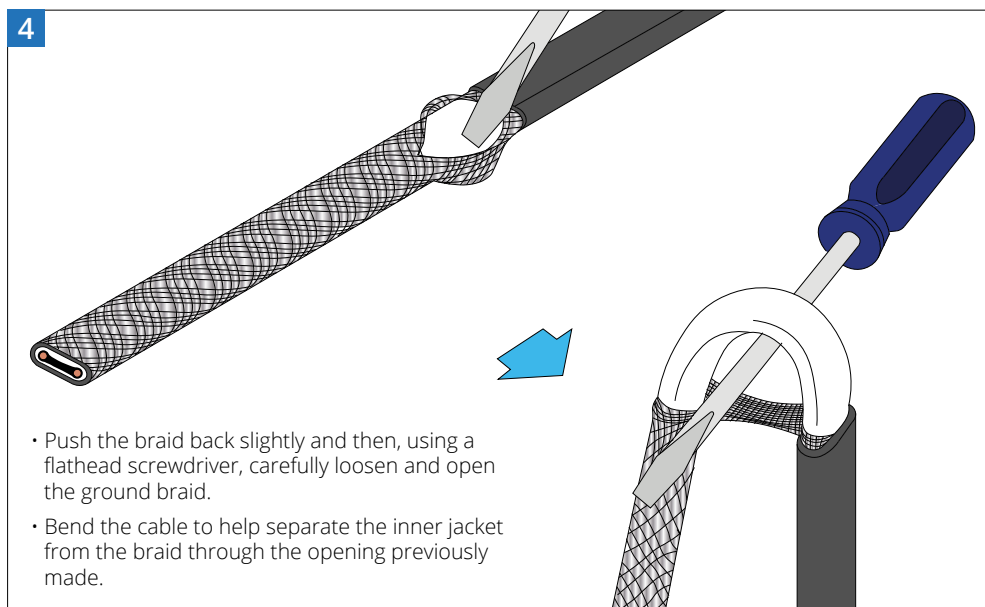

- Push the braid back slightly and then, using a flathead screwdriver, carefully loosen and open the ground braid.
- Bend the cable to help separate the inner jacket from the braid through the opening previously made.

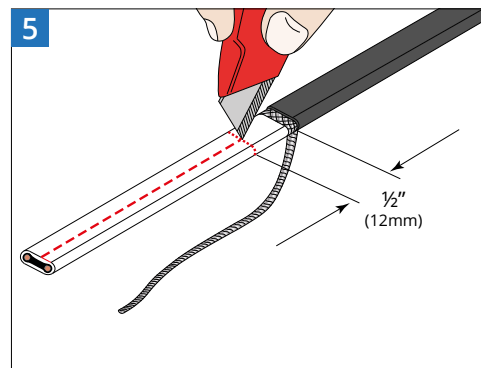

- Straighten the ground braid and leave to one side.
- Measure and mark approximately ½" (12mm) from the outer insulation up the inner insulation.
- Slice the inner insulation layer as shown. Bend the cable to break the inner jacket.

# Installation

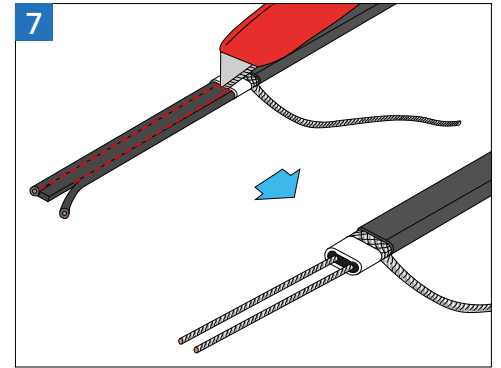
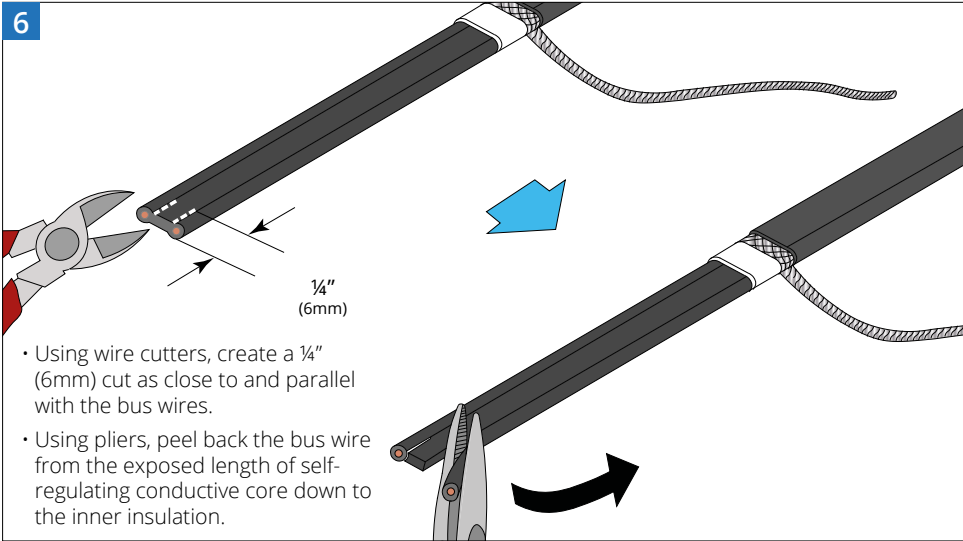

- Carefully slice and remove the self-regulating conductive core with the utility knife, ensuring you DO NOT CUT the bus wires.
- Ensure all of the core and any remaining materials are removed from the bus wires.
- Straighten and twist the bus wires.

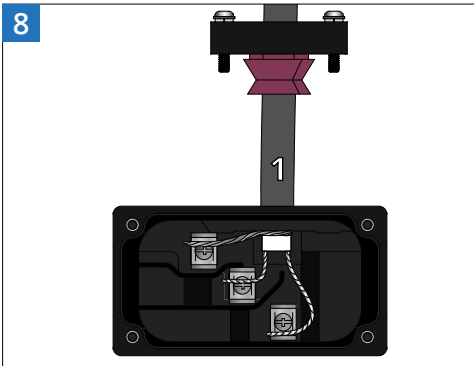

- Insert the 1st self-regulating cable into the SR-SFIT-TEE connection box bending the wires into position, cutting the excess off just 1/8" (3mm) past the terminals.

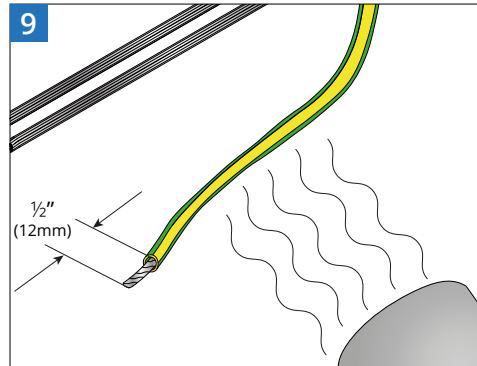

- Slide the Green & Yellow Heat-Shrink Tube; 1/4" ID x 6" (7 mm x 150 mm) through the ground braid. Cut the ground sleeve so that it is 1/2" (12mm) shorter than ground braid.
- Heat shrink onto the ground braid.

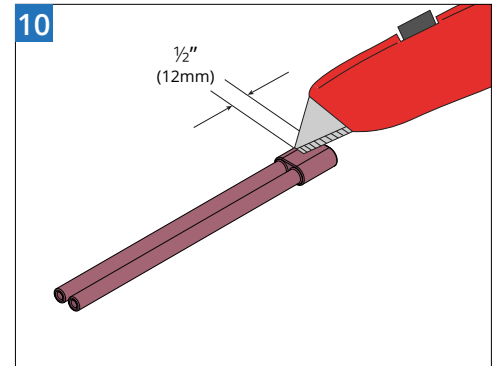

- Remove 1/2" (12mm) from the end of the silicone boot.

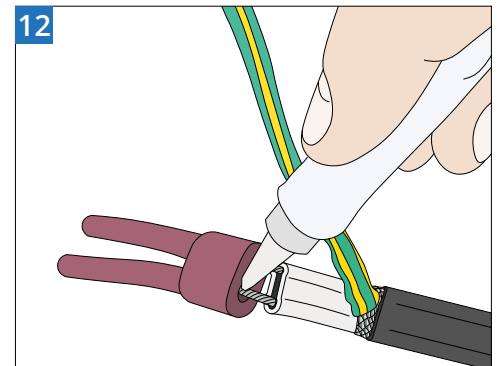
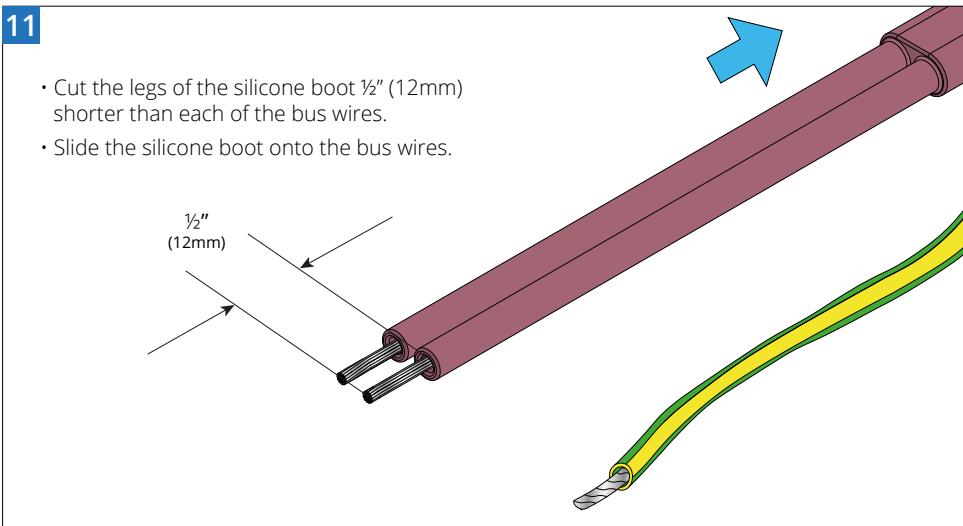

- Seal the ends of the silicone boot with a Natural Cure, Single Part RTV Adhesive.

13

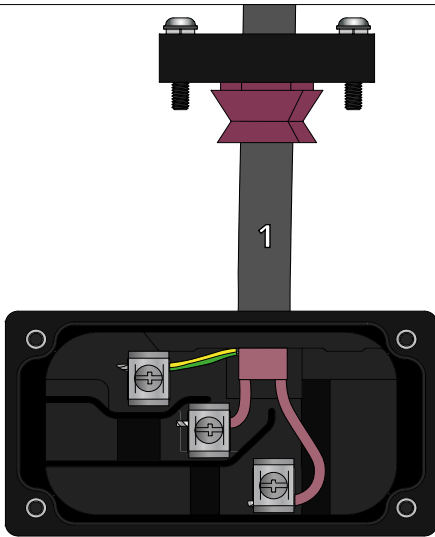

- Remove the screws, washers and clamps and place the cables onto the terminals on the connection box.
- Refit and tighten the 3 x screws, washers and clamps to secure the bus wires and ground braid in position. Trim any excess/ loose lengths of wire.

14

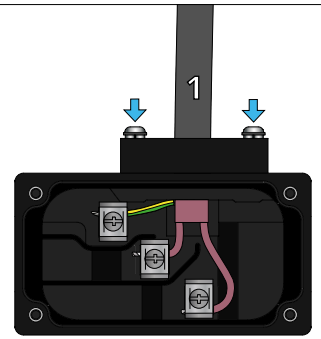

- Install the grommet into position in the connection box followed by the pressure end seal.
- Tighten the 2 x captive screws to the connection box.

15

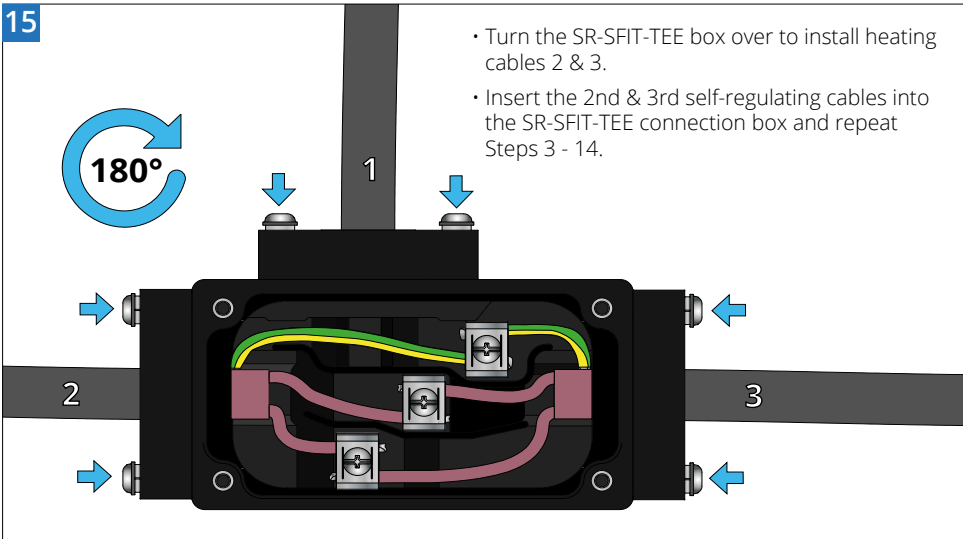

- Turn the SR-SFIT-TEE box over to install heating cables 2 & 3.
- Insert the 2nd & 3rd self-regulating cables into the SR-SFIT-TEE connection box and repeat Steps 3 - 14.

16

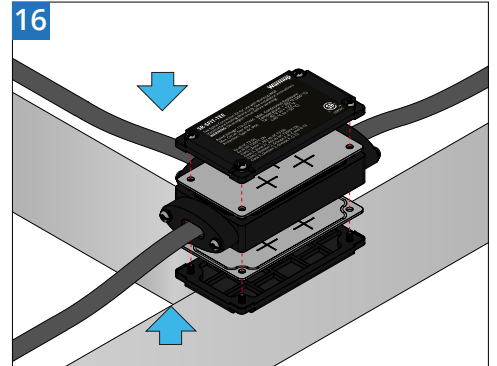

- Refit the gaskets and covers onto the body of the connection box.
- Tighten the 8 x captive screws to finish.

17

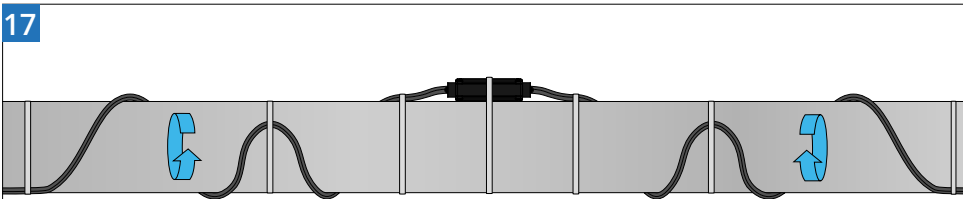

- Wrap the excess self-regulating cable around the pipe as shown to provide strain relief to the cable entering the SR-SFIT-TEE.
- Secure the self-regulating cable to the pipe at the locations shown to also provide additional strain relief. Use glass cloth tape to secure the cable to the pipe.

 You **MUST** provide additional and effective clamping of the cable to ensure that pulling is not transmitted to the terminations and prevent pulling and twisting after installation.

18

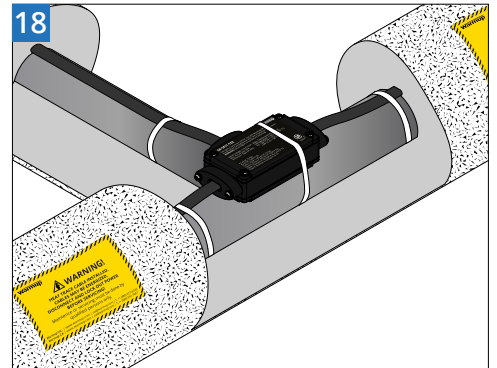

- Secure the SR-SFIT-TEE connection box to the pipe using glass cloth tape. Add extra tape on the cable as necessary to secure to the pipe.
- Add pipe insulation and cladding as per your design guide.
- Add the warning labels to indicate the presence of the installed self-regulating cable at intervals not exceeding 6 m (20 ft) along the pipeline or vessel and on or adjacent to equipment in the piping system that requires periodic servicing.



## Maintenance

---

A system inspection for freeze protection systems is recommended before the winter season. Category II systems should be inspected annually. All observations and measured values (as appropriate) should be recorded on a log sheet.

**Caution:** Always consult the self-regulating cable heating system documentation [cable & components] prior to maintenance / repair / modification.

The full maintenance requirements, including maintenance log sheet, are detailed in the WSR Self-Regulating cable manual. The SR-SFIT-TEE instructions must be used with reference to the installation instructions for the WSR Self-Regulating cable manual. Some maintenance procedures for the SR-SFIT-TEE include:

-  Junction boxes should be checked to verify that they are free of moisture and water. The thermal insulation and weather barrier should be inspected and repaired as needed.
-  The electrical insulation resistance of each circuit should be measured and recorded.
-  Major changes in insulation resistance or trace heater current should be resolved. In the event of an earth fault or over current interruption, the device shall not be reset until the cause of the trip has been investigated by qualified personnel.

## Technical Specifications

---

<b>Model</b>	SR-SFIT-TEE
<b>Operating Voltage</b>	110 - 120 V AC / 208 - 277 V AC
<b>Ambient Temperature Range (Ta)</b>	-40°F to +122°F (-40°C to + 50°C)
<b>Protection Grade</b>	Type 4X; IP66
<b>Maximum Circuit Size</b>	40 A
<b>Maximum Continuous Exposure Temperature</b>	392°F (200°C)
<b>Hazardous Locations Ratings Marking*</b>	Ex eb IIC T3 Gb, Ex tb IIIC T200°C Db Class I, Zone 1, AEx eb IIC T3 Gb Class II, Zone 21, AEx tb IIIC T200°C Db Class I, Division 2, Groups A, B, C and D T3 Class II, Division 2, Groups F, G T3
<b>Required Ground Fault Equipment Protection (GFEP)</b>	30mA
<b>Weight</b>	10 oz (282 g)

\* For hazardous locations, WSR self-regulating cable MUST be installed with Warmup approved accessories for hazardous locations





## Contact

---

Warmup is available 24/7/365 at (888) 927-6333  
For quotes, layouts and specific technical information contact us at:

### **Warmup Inc**

www.warmup.com  
us@warmup.com  
T: +1 (888) 927-6333

25 Francis J Clarke Cir, Bethel,  
CT 06801

### **Warmup Canada**

www.warmup.com  
ca@warmup.com  
T: 1+ (888) 592-7687

Please be advised Warmup Inc., provides these technical specifications and or instructions on a self help basis. We take every precaution to ensure they are accurate. Some of the products are sourced from manufacturers and we relay that information on to you. We do not have the technical specifications reviewed by an engineer and sometimes errors do happen. Our products are only reviewed with an ordinary level of care and when using said products in a situation that warrants additional care please be sure to conduct your own review. As such we strongly suggest before installing our products you have them reviewed by a professional engineer or qualified professional. We under no circumstances warrant our products for a particular use unless specifically agreed in writing.