

### PRODUCT CODES

DWM-XXX-XXX // DWM-Voltage-Wattage

### PRODUCT DESCRIPTION

The DWM floor heating mats are comprised of a low-profile twin conductor cable applied to a sturdy fiberglass mesh. The mats are self-adhesive on both sides and allow freedom of design and speed of installation thanks to the pre-spaced format of the heating cable.

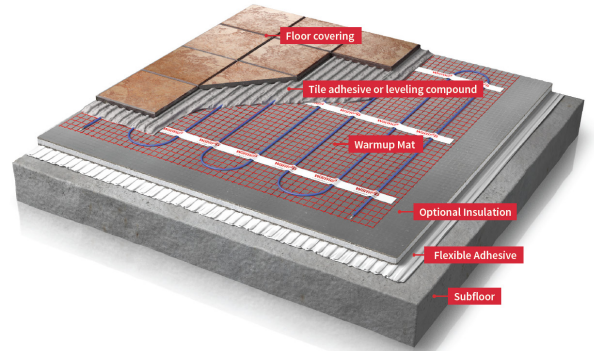

### ADVANTAGES

- The DWM mats have been specifically designed to provide Primary Heating under a variety of floors. The cable has been pre-assembled onto the mat to allow for an easy 'tape-down' installation. At 132°F peak cable temperature, the DWM system heats up fast and has been tested and proven to provide 70°F ambient temperature at 4ft in height in 1 hour.
- The DWM mats come with double-sided tape on both sides for a flexible installation over all subfloors. Warmup's StickyMAT range also provides for a pressure-sensitive adhesive on the mesh to ensure a very low installation profile.
- Using the 4iE® Programmable Thermostat, the product can be programmed to suit the user's needs. The 4iE® monitors the systems' power usage and will optimize comfort and consumption costs. The 4iE® controller combines the efficiency of built in floor and room sensors.
- The cable on the DWM mats is insulated with ETFE advanced fluoropolymers both on the conductors and the outer jacket for maximum protection. The system is fully grounded with a 10ft lead cable for connection to power.

### LIMITATIONS

- Do not cut the cable or apply the cable with staples. Apply caution to avoid nailing through the cable and avoid installation under permanent fixtures.
- The DWM mat is designed for primary heating provided the subfloor is properly insulated. Refer to Warmup's Warmup Insulation Boards (WIB) to provide additional insulation over uninsulated slabs on grade.

### SPECIFICATIONS

Operating voltage	120V, 208V & 240V; 50/60Hz
Width	20" (500mm)
Mat thickness	1/8" (3mm)
Inner / Outer Insulation	Advanced fluoropolymer (ETFE)
Output rating	14W/sq ft
Coil tail length	10ft (3m)
Approvals	cULus





The world's **best-selling** electric floor heating brand™

# FLOOR HEATING SYSTEM ON PRE-ASSEMBLED MATS SUBMITTAL SHEET WSC-0720

## TECHNICAL DATA

### Applications

Suitable Floor Coverings	Tile, Stone, Porcelain
	Vinyl and LVT's
	Glued-down carpet
	Glued-down wood
Suitable Sub-Floor	Plywood & OSB
	Polymer-modified leveler
	Concrete slab
	Cement boards
	Insulation Boards with cementitious coating
Min. coverage	3/8" thinset or self-leveling compound
Max. coverage	3/4" thinset or self-leveling compound

Installation under	Tile, Stone, Porcelain
	Clean the subfloor from debris and sharp protusions
	Consider deflection and structural aspects prior to installation
	Verify resistance of cable per instructions prior to install
	Connect multimeter or "alligator" tester provided
	Lay out the mat using the pre-applied double-sided tape
	Install floor sensor (supplied with controller)
	Consider scratch coat or thin leveler prior to installing floor covering
	Install floor covering per manufacturer's instructions

Installation under	Glued-down floors (LVT, Wood, Carpet)
	Clean the subfloor from debris and sharp protusions
	Ensure subfloor is level, if needed level, the floor first
	Verify resistance of cable per instructions prior to install
	Connect multimeter or "Alligator" tester provided
	Apply mat to subfloor using pre-applied double-sided tape
	Install floor sensor (supplied with controller)
	Cover the mat with self-leveling material, min.3/8" max. 3/4"
	Install floor covering per manufacturer's instructions

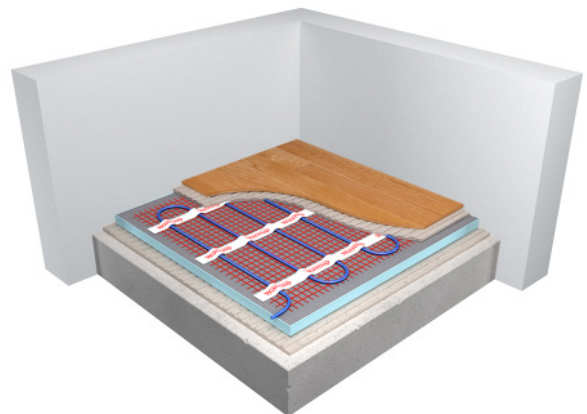
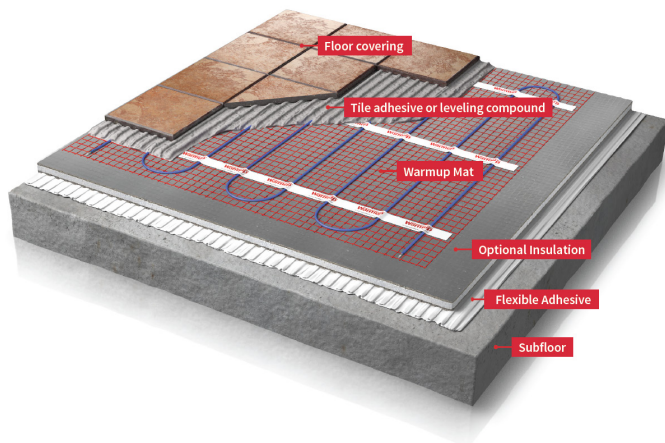



The world's **best-selling** electric floor heating brand™

# FLOOR HEATING SYSTEM ON PRE-ASSEMBLED MATS

## SUBMITTAL SHEET WSC-0720

### PRODUCT SIZE LISTINGS

Area (ft <sup>2</sup> )	Code	Mat Length (ft) (20" wide)	Wattage (W)	Amps (A)	Resistance (Ω)
10	DWM-120-140	6'	140	1.2	102.8
15	DWM-120-210	9'	210	1.8	68.5
20	DWM-120-280	12'	280	2.3	51.4
25	DWM-120-350	15'	350	2.9	41.2
30	DWM-120-420	18'	420	3.5	34.3
40	DWM-120-560	24'	560	4.7	25.7
50	DWM-120-700	30'	700	5.8	20.6
60	DWM-120-840	37'	840	7.0	17.1
75	DWM-120-1050	46'	1050	8.8	13.7
90	DWM-120-1260	55'	1260	10.5	11.4
110	DWM-120-1540	67'	1540	12.8	9.4
120	DWM-120-1620	73'	1620	13.5	8.9
25	DWM-240-350	15'	350	1.5	164.6
40	DWM-240-560	24'	560	2.3	102.9
50	DWM-240-700	30'	700	2.9	82.3
75	DWM-240-1050	46'	1050	4.4	54.9
90	DWM-240-1260	55'	1260	5.3	45.7
110	DWM-240-1540	67'	1540	6.4	37.4
150	DWM-240-2100	91'	2100	8.8	27.4
180	DWM-240-2520	110'	2520	10.5	22.9
220	DWM-240-3080	134'	3080	12.8	18.7
240	DWM-240-3240	146'	3240	13.5	17.8

Area (ft <sup>2</sup> )	Code	Mat Length (ft) (3' wide)	Wattage (W)	Amps (A)	Resistance (Ω)
9	DWM-09-120	3 X 3	126	1.05	114.3
15	DWM-15-120	3 X 5	210	1.75	68.5
18	DWM-18-120	3 X 6	252	2.10	57.1
24	DWM-24-120	3 X 8	336	2.80	42.9
30	DWM-30-120	3 X 10	420	3.50	34.3

WARMUP INC.  
USA: us@warmup.com  
Tel.: 1-888-927-6333  
www.warmup.com

CANADA: ca@warmup.com  
Tel.: 1-888-592-7687  
www.warmup.ca



The world's **best-selling** electric floor heating brand™

### WIRING DIAGRAM 120V



Isolate the thermostat from the mains supply throughout the installation process

Heating Load connected to 4iE - Max. 15 Amps

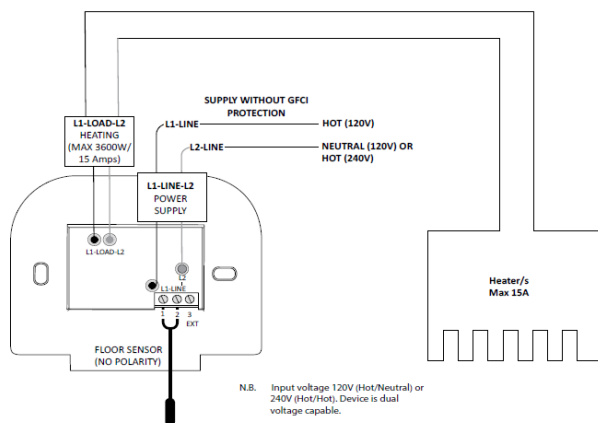

### WIRING DIAGRAM 208V & 240V

Heating Load connected to Relay 25 - Max. 25 Amps

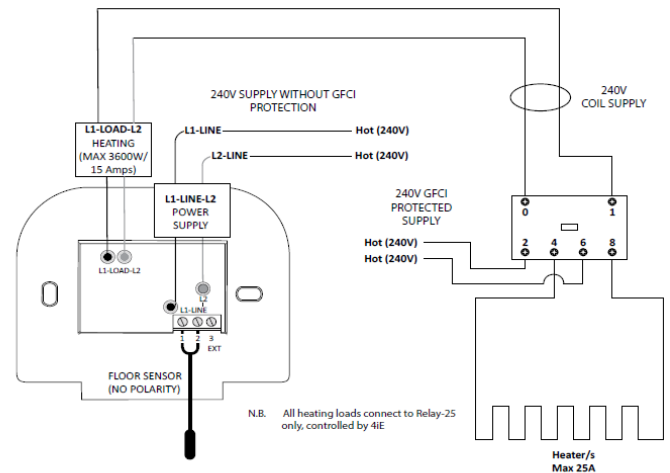

### WARRANTY & MAINTENANCE

When installed according to the installation manual and proper testing has been performed throughout, the system requires no maintenance for the duration of its warranted life.

The DWM mat is warranted for 30 years against manufacturer's defects and is protected by Warmup's SAFETYnet guarantee. See [www.warmup.com](http://www.warmup.com) for full warranty details.



### TECHNICAL SUPPORT

Warmup is available 24/7/365 at (888) 927-6333.

For quotes, layouts and specific technical information, contact us at:

**Warmup USA**  
(888) 927-6333  
[ussales@warmup.com](mailto:ussales@warmup.com)

**Warmup CANADA**  
(888) 592-7687  
[ca@warmup.com](mailto:ca@warmup.com)

### RELATED PRODUCTS

- Warmup Insulation Boards - see WSC-0725
- 4iE® Smart WiFi thermostat - see WSC-0926